

Tondo PDF 1200

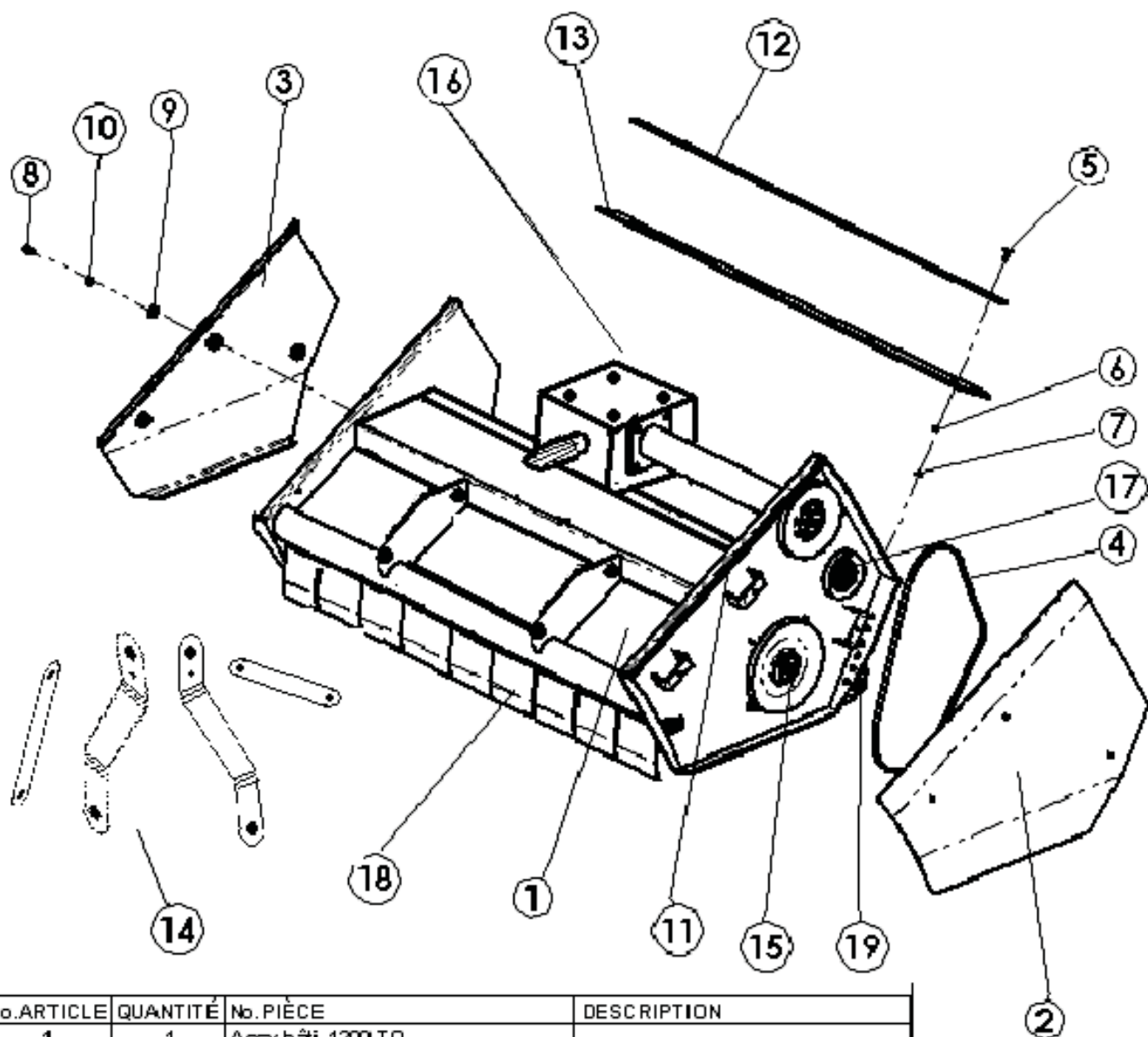

No. ARTICLE	QUANTITÉ	No. PIÈCE	DESCRIPTION
1	1	Assy bâti 1200 TQ	
2	1	Carter D (embouti)	
3	1	Carter G	
4	1	Courroie Spa X 1250	
5	5	Vis Poeli ère M6x20 zn	
6	5	Rondelle contact 6 zn	
7	5	Ecrou HM6	
8	6	Vis HM 8x20	
9	6	Rondelle plate L8U zn	
10	6	Rondelle contact 8 zn	
11	2	Joint caoutchouc mousse (5x10)	
12	1	Plat de bavette 1200	
13	1	Bavette CC 1200	
14	1	Attelage complet	
15	1	Rotor	
16	1	Boitier	
17	1	Poulietendeur	
18	1	Assem petites bavettes + tige	
19	1	Rouleau	

Rotor + poulie tendeur

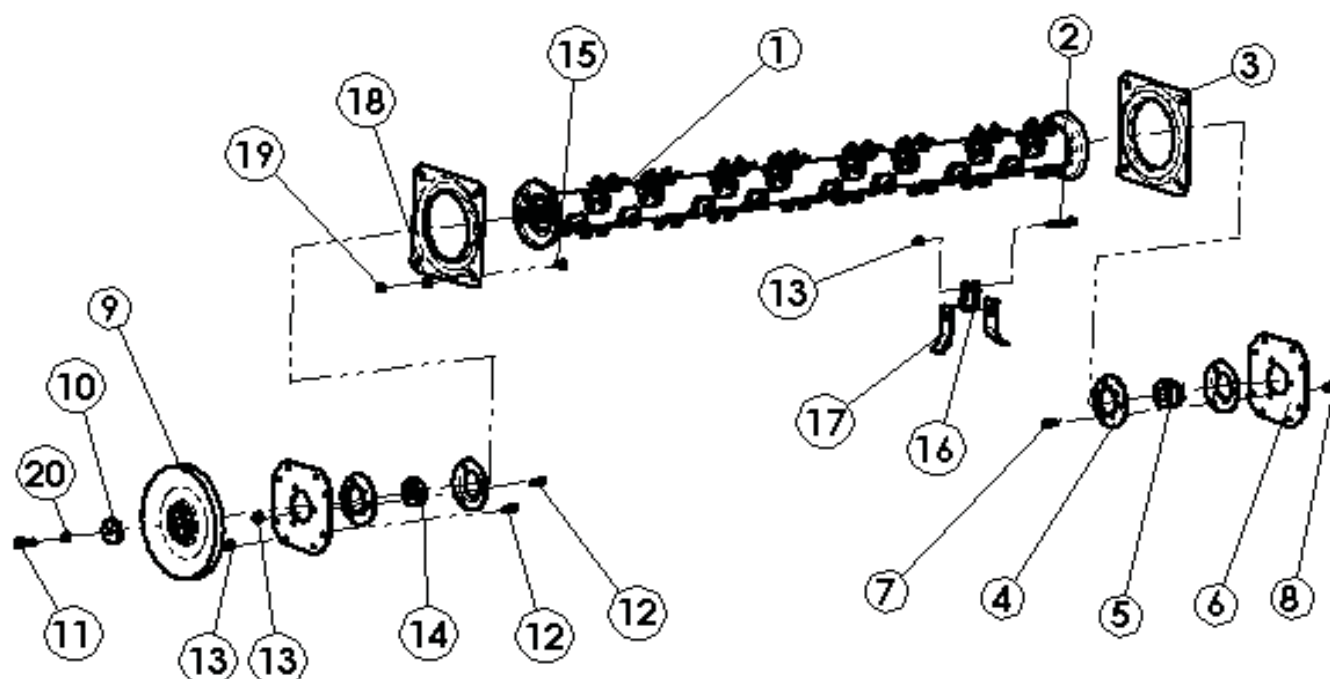

No. ARTICLE	QUANTITÉ	No. PIÈCE	DESCRIPTION
1	1	Corps de rotor 1200	
2	48	Vis CHC 8x50	
3	2	Défecteur interne	
4	4	PF 52	
5	1	YET 205	
6	2	Support palier	
7	3	Vis HM8x20	
8	3	Ecrou frein M8 (haut)	
9	1	Poulie A200 + moyeu	
10	1	Rondelle M10 46x8	
11	1	Vis HM 10x30	
12	19	Vis HM8x16	
13	65	Ecrou frein M8	
14	1	1726 205	
15	8	Vis Poellière M8x16	
16	48	Manille	
17	2	Couteau Y4	
18	8	Rondelle contact 8 zn	
19	8	Ecrou HhM8 zn	
20	1	Rondelle W10	

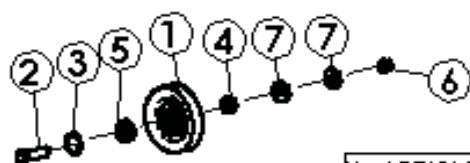

No. ARTICLE	QUANTITÉ	No. PIÈCE	DESCRIPTION
1	1	Poulie A100 + moyeu	
2	1	Vis HM 12x45 10.9	
3	1	Groclips intérieur 32x1.2	
4	1	Bague roulement tendeur	
5	1	Roulement 6201	
6	1	Ecrou frein M12	
7	2	Rondelle plate L12U zn	

Rouleau + petites bavettes

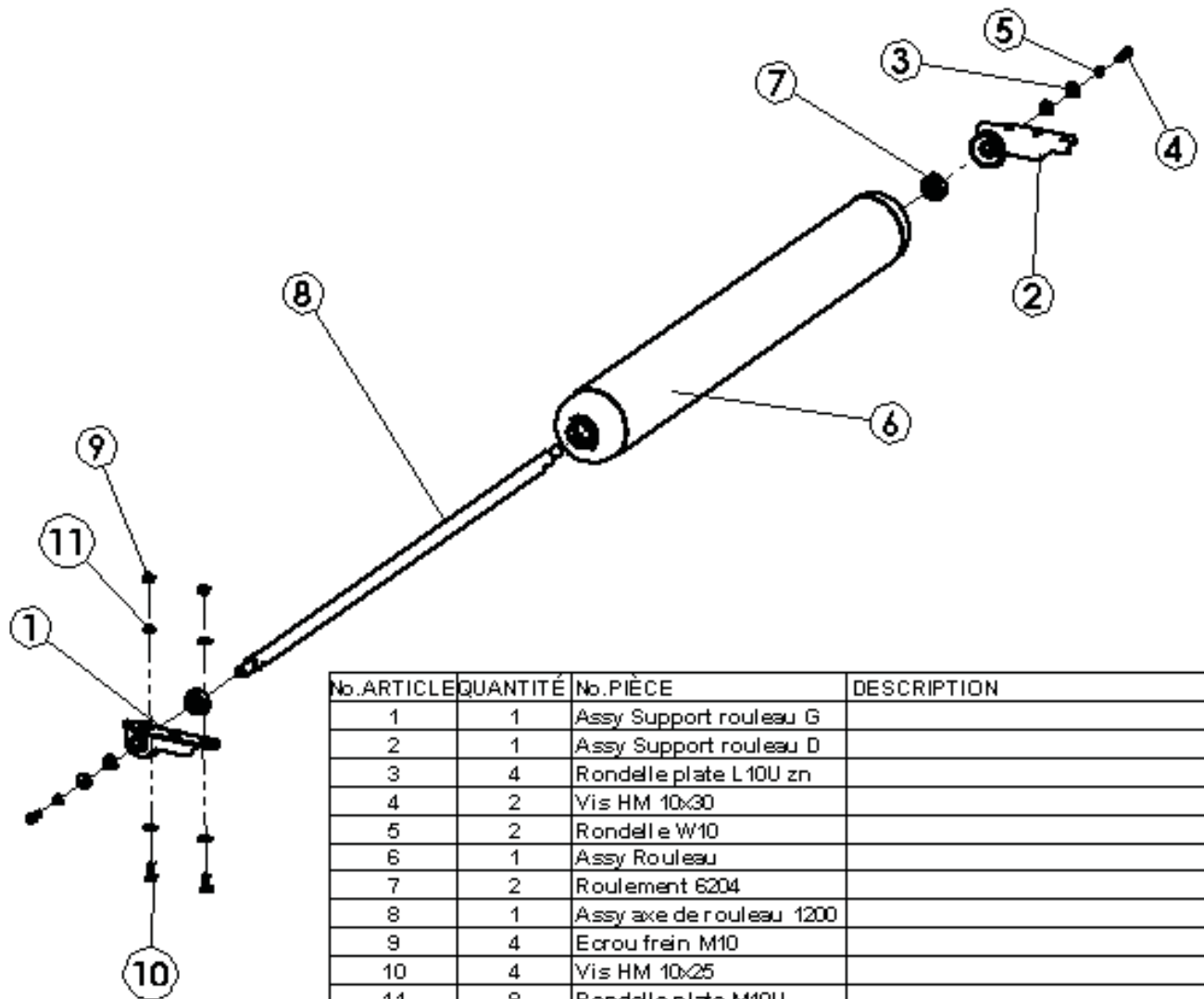

No. ARTICLE	QUANTITÉ	No. PIÈCE	DESCRIPTION
1	1	Assy Support rouleau G	
2	1	Assy Support rouleau D	
3	4	Rondelle plate L10U zn	
4	2	Vis HM 10x30	
5	2	Rondelle W10	
6	1	Assy Rouleau	
7	2	Roulement 6204	
8	1	Assy axe de rouleau 1200	
9	4	Ecrou frein M10	
10	4	Vis HM 10x25	
11	8	Rondelle plate M10U	

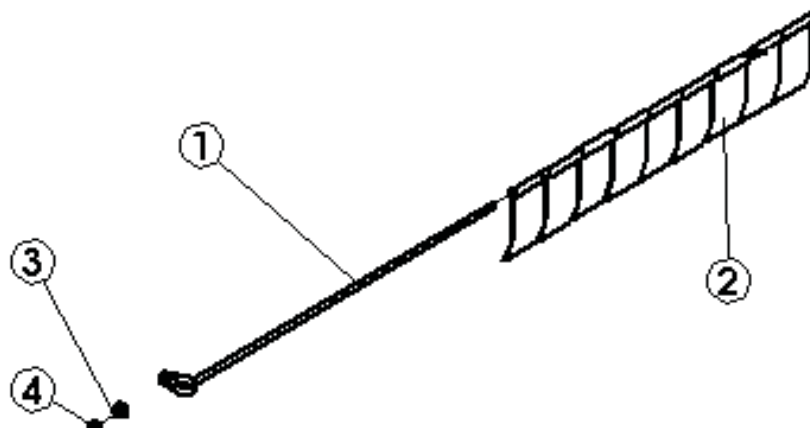

No. ARTICLE	QUANTITÉ	No. PIÈCE	DESCRIPTION
1	1	Assem tige de bavettes	
2	9	Assem petite bavette	
3	1	Rondelle plate L10U zn	
4	1	Ecrou frein M10	